

Optimized Truepath

Optimized for

2vrms source (Max input 2Vrms)

8 ohm speakers

Transformer 40Vrms at least 400VA (Rails +/-54VDC)

Sample Person

Truepath by 41Hz
Optimization by Audiophool

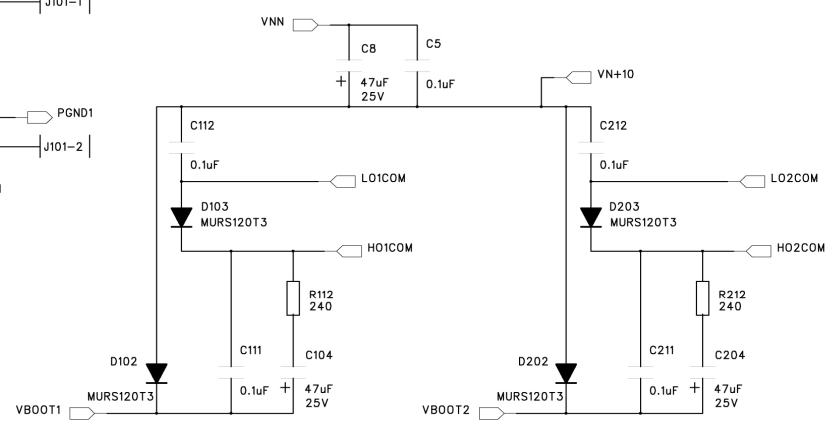
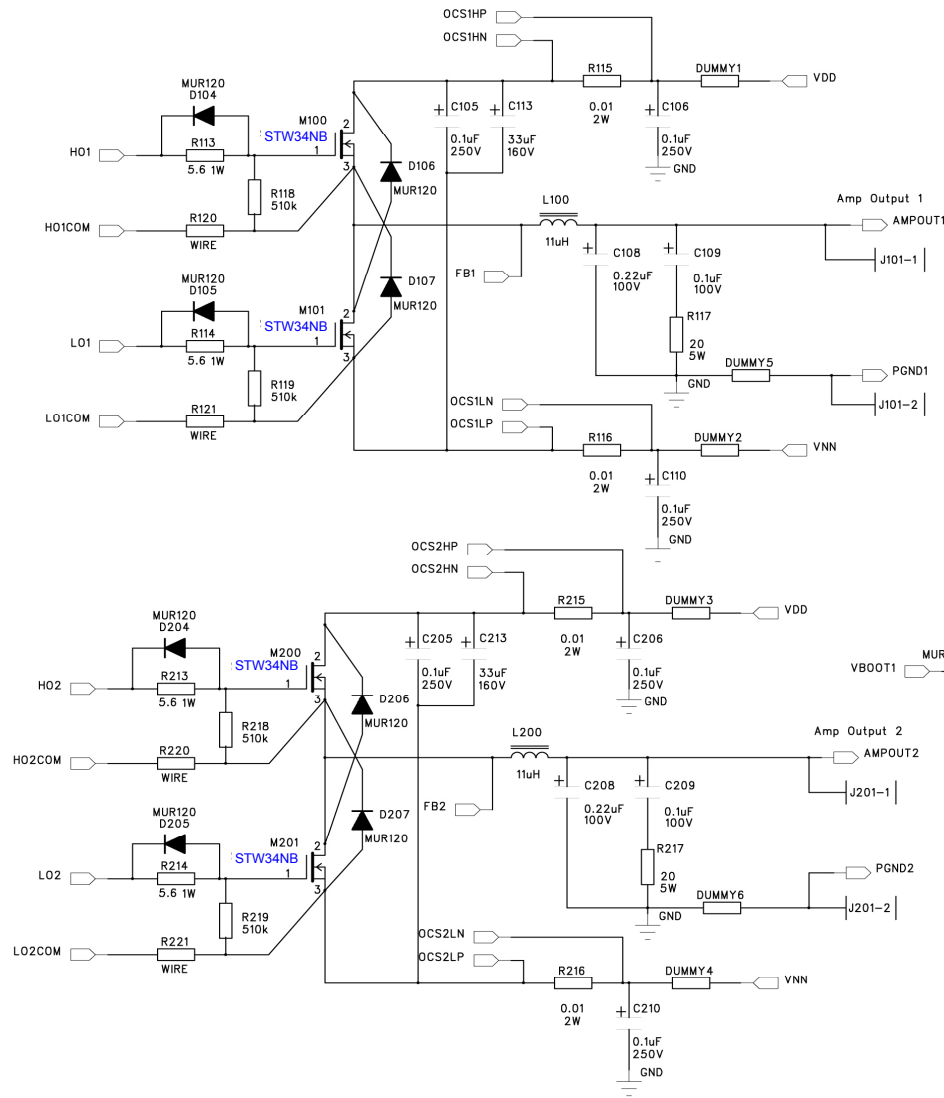

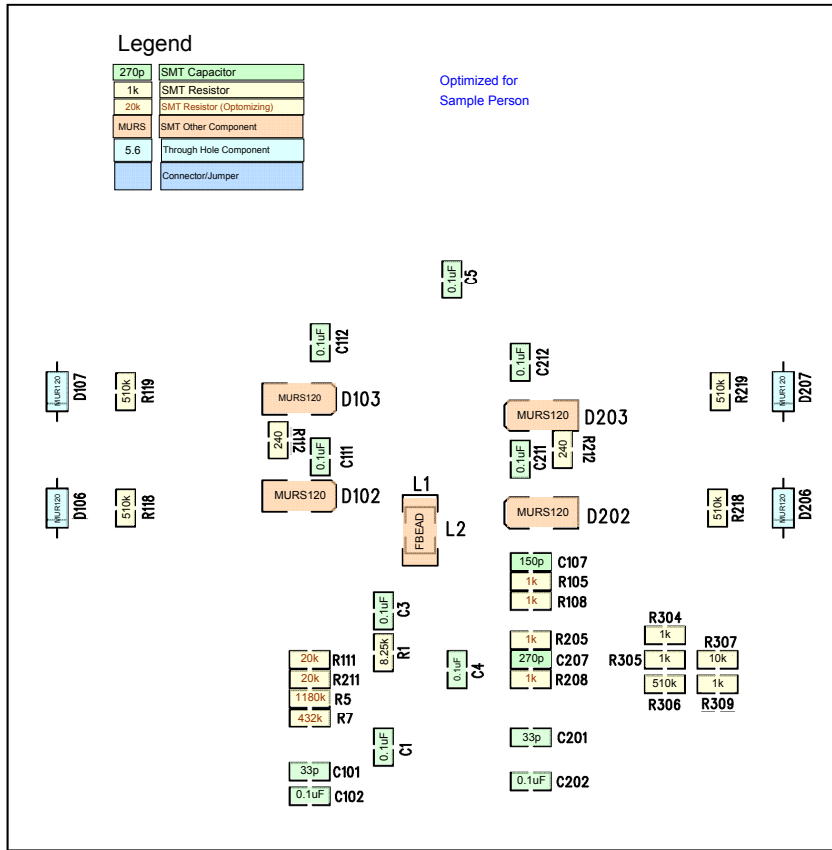
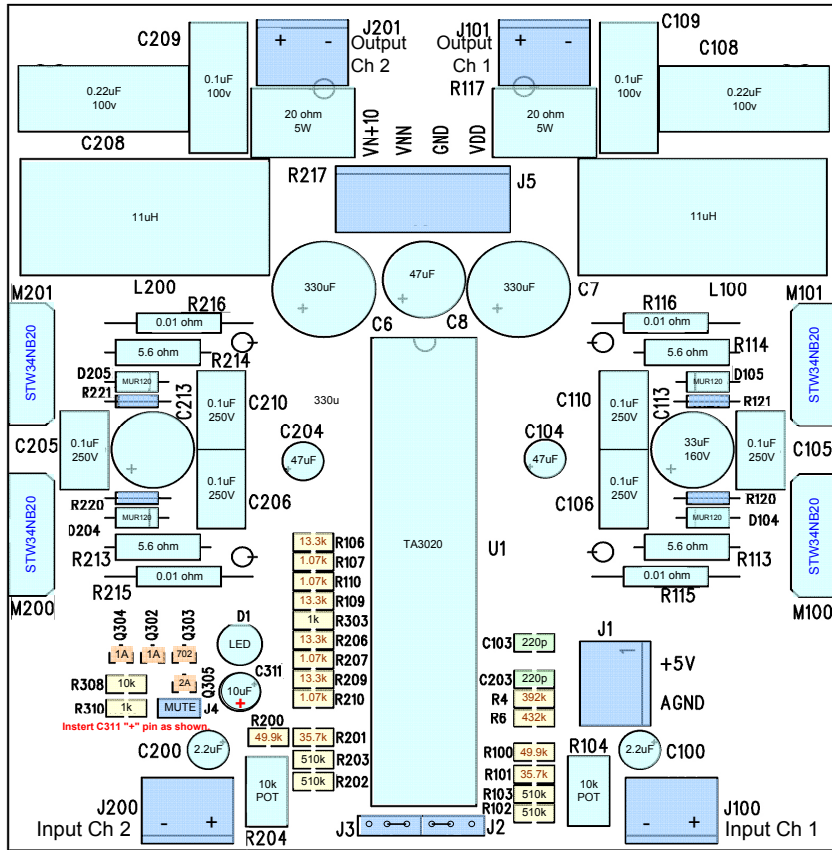

Truepath SMT Parts Sheet

Sample Person

	Pkg	Qty	Val/Mark	Paste SMT parts here	Bag
Resistor - Optimizing	0805	4	1k	In Kit	3
	0805	4	1.07k	In Kit	1
	0805	4	13.3k		
	0805	2	20k	In Kit	9
	0805	2	35.7k		
	0805	2	49.9k		
	0805	1	392k	In Kit	6
	0805	2	432k		
	0805	1	1180k		
Cap	0805	2	33p	In Kit	7
	0805	1	150p	In Kit	8
	0805	2	220p	In Kit	8
	0805	1	270p	In Kit	7
	0804	10	0.1u	In Kit	3
Resistor - Standard	0805	2	240	In Kit	5
	0805	5	1k	In Kit	3
	0805	1	8.25k	In Kit	6
	0805	2	10k	In Kit	6
	0805	9	510k	In Kit	7
Other	Diode	4	MURS120	In Kit	10
	Ferrite	1	Ferrite	In Kit	4
	SOT-23	2	1A	In Kit	10
	SOT-23	1	2A	In Kit	10
	SOT-23	1	702	In Kit	10